



* Illustration may contain items not standard to the model

KEY FEATURES

- Driver's SRS Airbag
- Manual or Automatic Transmission
- ABS Brakes with Electronic Brakeforce Distribution
- Ventilated Disc Front Brakes
- Corner Turning Lamps
- Energy Absorbing Steering Wheel
- Easy Start (Manual model)

KEY SPECIFICATIONS

GVM.	4495kg
GCM.	7300kg
Engine.	4.0-litre, Common Rail, Direct Injection, Turbocharged and Intercooled
Power	100kW @ 2700 RPM (ISO NET)
Torque.	358Nm @ 1800 RPM (ISO NET)
Wheelbase	2525mm





414

Engine & Driveline specifications

ENGINE

Engine	Hino N04C TU
Max output (ISO Net)	100kW (136 PS) at 2700 RPM
Max output (JIS GROSS)	103kW (140 PS) at 2700 RPM
Max torque (ISO Net)	358Nm (36.5 kgf/m) at 1800 RPM
Max torque (JIS GROSS)	364Nm (37.1 kgf/m) at 1800 RPM
Maximum engine speed	3200 RPM
Type	Diesel, four cycle, four-cylinder in line, overhead valve, water cooled
Combustion system	Direct injection type
Bore & stroke	104 x 118mm
Piston displacement	4.009 litres
Fuel injection system	Electronic control, common rail type CRS
Air intake system	Turbo-intercooled, front air intake
Air cleaner	Paper element
Fan clutch	Equipped
Catalytic converter	Equipped
Exhaust outlet	Horizontal
Emission control system	EGR meeting ADR80/02 using US04

CLUTCH

Clutch type	Dry single plate, diaphragm type with damper springs
Facing outside diameter	300mm
Facing lining area	423 x 2cm ²
Control	Hydraulic with vacuum booster

TRANSMISSION

Manual	M550
Type	Five-speed overdrive manual
Auto	A860E
Type	Six-speed electronically controlled overdrive automatic with torque converter lock-up on 2nd, 3rd, 4th, 5th and 6th gears
Hill Descent Control	Equipped

BRAKES

Service brakes	Hydraulic system with ventilated disc brake for front and drum brake for rear with automatic adjuster
Control	Vacuum servo with hydraulic assist & dual circuits
Front disc diameter	296mm
Rear drum size	320mm x 83mm
Anti-lock system (ABS)	Equipped
Electronic Brakeforce Distribution (EBD)	Equipped
Exhaust Brake	Electric-vacuum actuator with valve in exhaust pipe
Easy Start	(Manual Model only)

PERFORMANCE & GEAR RATIOS

	Manual	Auto
Engine RPM @ 100km/h	2685	2420
Maximum speed (km/h)	119	132
Gradeability tan θ % @ GVM	60.0	60.0
Final drive ratio	5.125:1	5.375:1

M550

1st4.981	4th1.000
2nd2.911	5th0.738
3rd1.556	Rev.4.625

A860E

1st3.742	5th0.773
2nd2.003	6th0.634
3rd1.343	Rev.3.697
4th1.000		

AXLE LOAD & TYRE LOAD LIMITS

Front axle	2600kg
Tyre	2180kg
Rear axle	4400kg
Rear axle tyre rating	2800kg
Front axle type	Reversed Elliot, "I" section beam
Rear axle type	B265, full-floating, single reduction, single speed by Hypoid gears

SUSPENSION

Front suspension	Semi-elliptic tapered leaf springs with silencers, shock absorbers and stabiliser bar
Spring dimensions, span & width	1210mm x 70mm
Rear suspension	Semi-elliptic main and auxiliary tapered leaf-springs with silencers and shock absorbers
Spring dimensions, span & width	1210mm x 70mm
Auxiliary springs	860mm x 70mm

WHEEL & TYRES

Wheel type	5-stud disc wheel
Front wheel & rim size	185/85R16 111/109 & 16x5.5K-113mm
Rear wheel & rim size	215/85R16 120/118 & 16x5.5K-113mm
Number of tyres	Five including spare
Spare tyre carrier	Equipped

ELECTRICAL

Type	24 volt, negative earth
Batteries	2V x 2, series connected
Alternator type	Built-in rectifier and voltage regulator
Capacity	24V – 60-A
Starter capacity	24V, 4.5kW



414

Cab equipment & Instrumentation



CAB EXTERIOR

Type	Forward control, all steel welded construction, torsion-bar tilt mechanism, fully trimmed
Windscreen wipers	Electric, dual wipers, intermittent and 2-speed
Outside rear mirrors	Two, movable flat type
Radiator grille	Painted same colour as cabin
Lamps	Halogen headlamps, cornering lamps, fog lamps

CAB INTERIOR

Steering	Telescopic tilt column with integral power steering
Windscreen glass	Laminated glass
Seating capacity	Three
Driver's seat	2-way adjustable, urethane foam pads, high-back seat
Assistant's seat	Fixed, urethane foam pads, high-back seat
Seat cover	Fabric cover
Seat belts	
Driver's seat	3-point type with ELR and pre-tensioner
Assistant's seat	3-point type with ELR
Centre passenger's seat	2-point type
Sun visors	For driver and passenger
Ventilator	Forced type by electric blower
Inside rear mirror	One, flat type
Cigarette lighter (24 volt)	Equipped
Audio	AM/FM radio with CD player
Heater and defroster	Equipped
Air conditioner	Equipped
Auto door lock	Equipped
Power windows	Equipped
SRS airbag	Equipped for driver
Seat back console	Equipped (centre)
Overhead consoles	For driver and assistant
Ash tray: 2-pcs	Equipped
Door pockets (both sides)	Equipped
Assist grip	Equipped
Coat hook	Equipped
Card holder	Equipped
Pen holder	Equipped
Cup holder	Equipped

POWER & TORQUE CHART (ISO Net) N04C TU

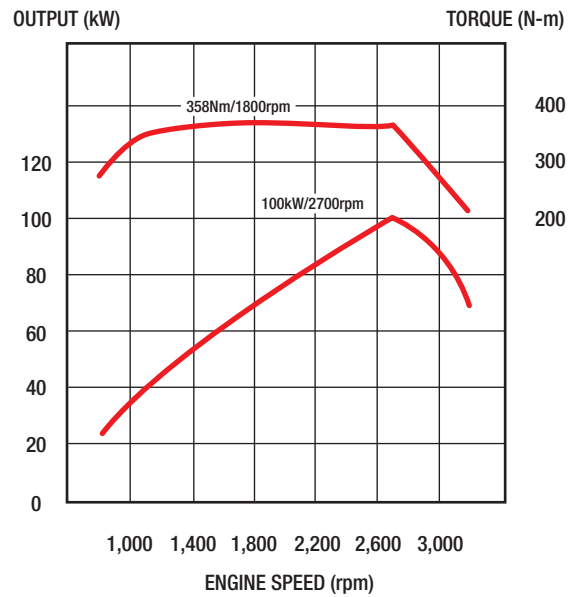

CHASSIS FRAME

Type	Ladder-shaped channel section side rails
Chassis width at rear	700mm
Max. section	
(depth x flange x thickness)	180 x 65 x 6.0mm
Tensile strength	440N/mm ²
Towing hooks	Equipped at front and rear
Front bumper	Painted to cabin colour

INSTRUMENTS

1. Meter and gauges	Engine oil pressure lamp
km-kg system	Battery charge lamp
Speedometer	High beam indicator lamp
Fuel gauge	Parking brake indicator lamp
Coolant temperature gauge	Engine malfunction indicator lamp
Engine tachometer	Transmission oil temperature lamp
2. Switches	Fuel level lamp
Lighting	Fuel filter water accumulating level lamp
Directional indicator, dimmer, passing	Brake fluid level lamp
Room lamp	Back-up buzzer
Hazard lamp	Cab-tilt lamp
Wiper and washer	ABS system failure lamp
Exhaust brake	SRS airbag system failure lamp
3. Warning lamps and buzzers .	
Turning signal & hazard indicator lamp	
Exhaust brake indicator lamp	
4. Others	One-key starting-stopping
	Horn button

STEERING

Type	Telescopic and tilt steering column with locking device. Recirculating ball with integral power steering
Gear ratio	22.6
Steering angle	Inside: 36-39° Outside: 29°



414 Dimensions

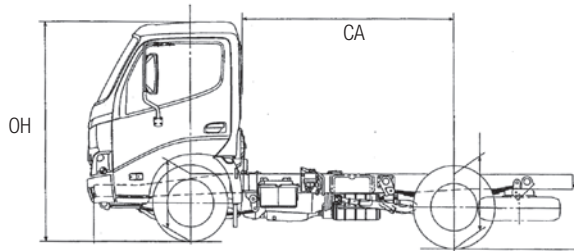
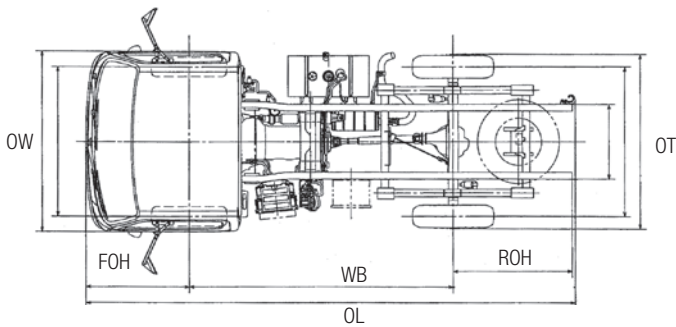
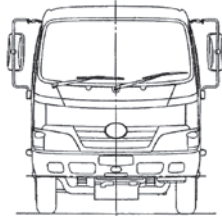

DIMENSIONS - mm / Capacities

Model	414 Manual	414 Auto
Production code	XZU307R-HKMLBQ3	XZU307R-HKTLBQ3
Wheelbase (WB)25252525
Front track14001400
Rear track14001400
Overall Tyre width (OT)16101610
Overall length (OL)46754675
Overall width (OW)16951695
Overall height (OH)20752075
Cab to axle centre (CA)20252025
Front overhang (FOH)980980
Rear overhang (ROH)11351135
Front chassis height635635
Rear chassis height695695
Road clearance185185
Turning circle kerb to kerb10,40010,400
Turning circle wall to wall11,50011,500
Fuel tank capacity – lt8080
Chassis mass – kg (standard tools, 10 litres of fuel, without spare tyre)		
Total19202010
Front13401415
Rear580595
GVM44954495
GCM73007300

GENUINE ACCESSORY OPTIONS

Bull bar	Roof scoop
Chrome wheel covers	Side skirts
Electric mirrors	Stoneguard
Multimedia sat nav	Sunvisor
Rear vision camera	Timber dash panel

Please check with your dealer for price, availability & fitment for these options

WARRANTY

New vehicle warranty period

Light Duty Model	Axle configuration	Standard warranty (whichever comes first)	Cab corrosion perforation
300 414	4 x 2	3 years or 100,000km	36 months

Battery warranty – 12 months from date of delivery

Genuine parts or accessories warranty – 3 years unlimited kilometres when fitted by an authorised Hino dealer *

* For conditions, refer to the Hino Parts & Service warranty brochure

DISCLAIMER

Important notice. Hino Trucks are distributed in Australia by Hino Motor Sales Australia Pty Ltd A.C.N. 064 989 724.

All efforts have been made to ensure the information contained in this brochure was correct at time of printing or uploading. Hino Motor Sales Australia Pty Ltd reserves the right to alter any details of the specifications & equipment without notice. Hino in so far as it is permitted by law to do so, shall not be liable in any way as a result of any reliance placed by any person on anything contained in this brochure. You should therefore check with your authorised Hino dealer at the time of ordering your motor vehicle to ensure that colour, specifications, equipment, design features & options are available for the vehicle you are ordering. Please note that some options may only be available in combination with others. Authorised Hino dealers will on request provide up to date information on all accessories, design features, prices & availability.

Date of issue - 01/01/10 414 v2.X